

# ASSEMBLY INSTRUCTIONS

## CAD Mobile Project File

*PLEASE NOTE. Do not tighten bolts fully until all parts are in position.*

- STEP 1.** Locate the joining bracket (2) between the two 'H'-shaped square tube sides (1) and fix with 4 x screws and washers (3).
- STEP 2.** Screw the 4 x castors (4) into nutserts on bottom of side frames.
- STEP 3.** Tighten all bolts.
- STEP 4.** Fix bottom end-caps (5) and top end-caps (6).

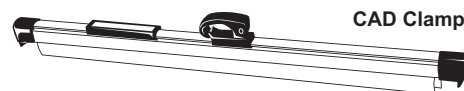
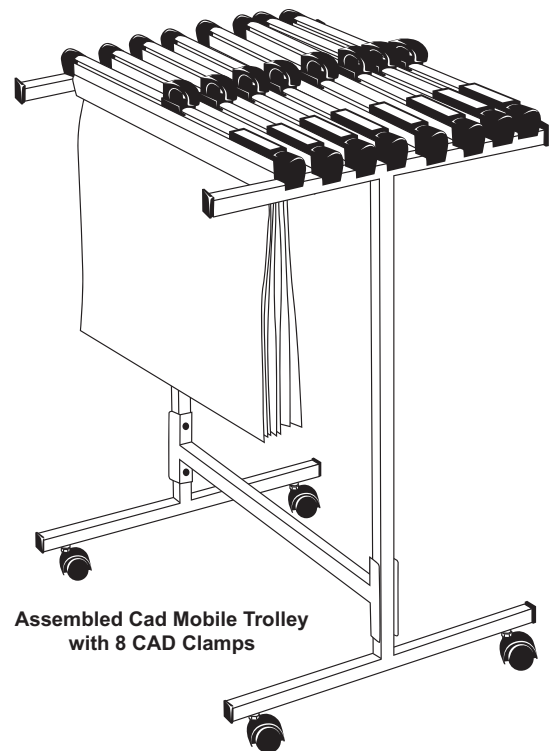
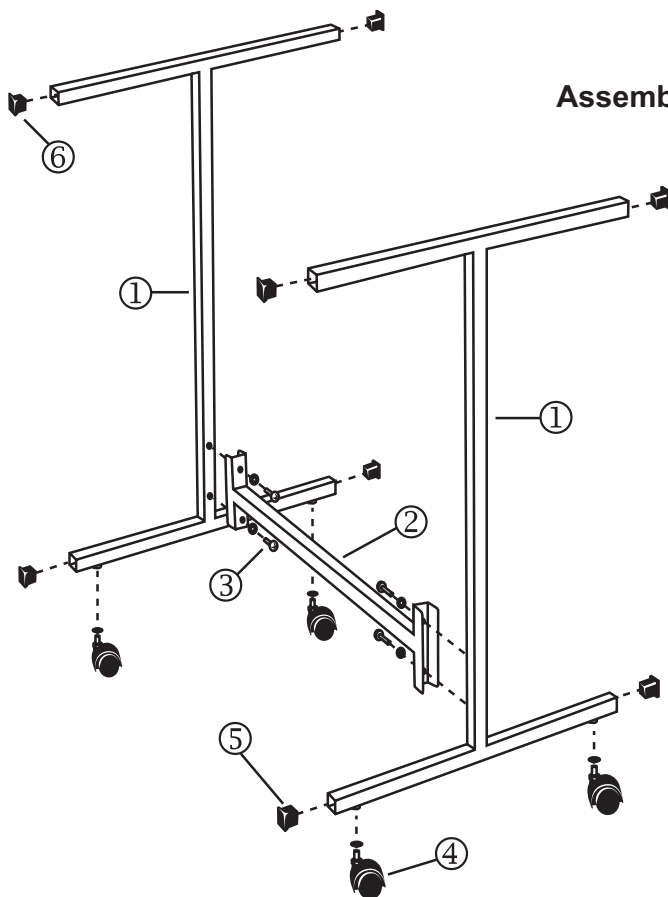

### CONTENTS

- 2 x 'H'-shaped square tube
- 1 x Joining bracket
- 4 x Bottom end-caps
- 4 x Top end-caps
- 4 x Castors
- 4 x Screws with washers
- 1 x Spanner/Screwdriver
- 8 x A3 CAD clamps