

ASSEMBLY INSTRUCTIONS

Hang-A-Plan General Front Loader Trolley

- STEP 1.** Do not tighten any bolts until all parts are in position.
- STEP 2** Locate the back plate (Fig.3) on side frames (Fig.2) and fix with bolts and washers (4 only 8 x 20mm bolts and washers) (Fig.4 & 5).
- STEP 3.** Screw 2 only 8 x 20mm bolts and 2 washers (Fig.4&5) into bottom of side frames through base plate (Fig.3).
- STEP 4.** Screw 2 castors (Fig.6) into nutserts on bottom of side frames through base plate (Fig.3).
- STEP 5.** Screw remaining 2 castors (Fig.6) with washers into nutserts on rear bottom of side frames (Fig.2).
- STEP 6.** Place the top channel (Fig.1) in position on top of side frames (Fig.2) and fix with bolts and washers (4 only 8 x 20mm bolts and washers) (Fig.4&5).
- STEP 7.** Tighten all bolts.
- STEP 8.** Hang the binders onto the top channel using the small clip on the handle of

The General Front Loader Trolley is now ready for use.

Assembly Chart

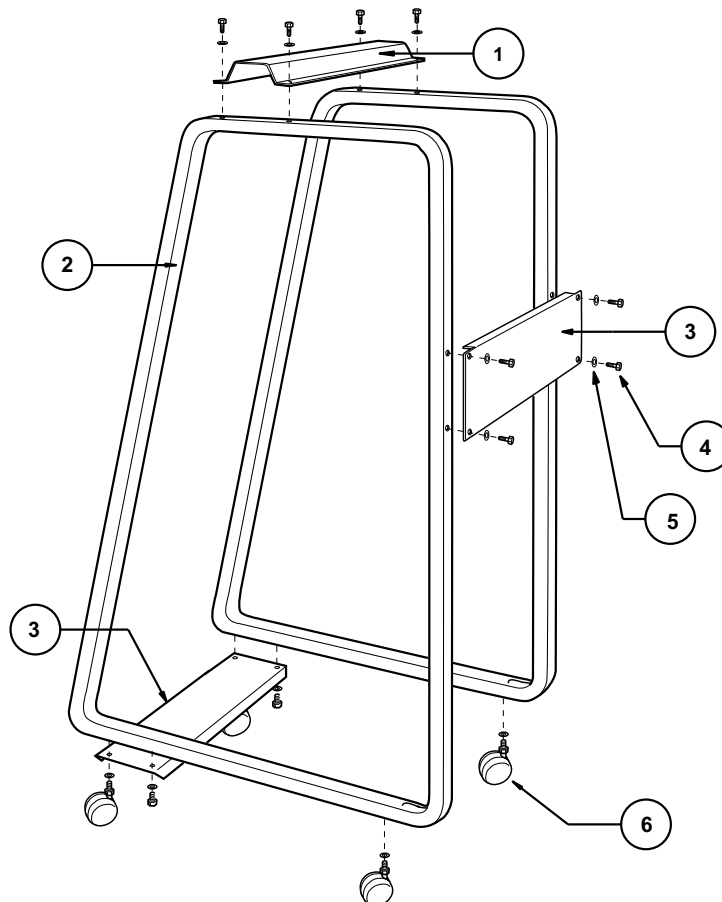

CONTENTS

1. Top channel	Qty. 1	4. 8 x 20mm hex head bolts	Qty. 10
2. Side frame	Qty. 2	5. 8 x 16mm flat washers	Qty. 14
3. Back plate/base plate	Qty. 2	6. Castors	Qty. 4