

ASSEMBLY INSTRUCTIONS

Premium Front Loader Trolley (Optional Systems Shelf Shown)



PLEASE NOTE

Do not tighten bolts fully until all parts are in position

TROLLEY

Use the combination spanner supplied for easy assembly.

1. Locate the back plate (fig. 3A) between frames (fig. 2) and fix with four 8 x 20mm bolts and washers (fig. 4 & 5).
2. Screw two bolts and washers into bottom of side frames through base plate (fig. 3B).
3. Screw two castors (fig. 6) into nutserts on bottom of side frames through base plate (fig. 3B). Screw 1 castor into nutsert on centre of base plate.
4. Screw remaining two castors with washers into nutserts on rear of side frames.
5. Place the top channel (fig. 1) in position on top of side frames and fix with four 8 x 20mm bolts and washers.
6. Tighten all bolts with the combination spanner supplied.

OPTIONAL SYSTEMS SHELF

7. Place the systems shelf (fig. 7) on the top channel (fig. 1) with the open side facing forward, away from the back plate (fig. 3A). Slide the two fixing brackets (fig. 8) into notches on both sides of the systems shelf and fix with 1/4" bolts (fig. 9) and washers (fig. 10) into the nutserts on each side of the top channel.

**Your HANG-A-PLAN PREMIUM FRONT LOADER TROLLEY
is now ready for use**

You can now hang your Hang-A-Plan front loader binders (purchased separately) onto the top channel, using the small clip on the handle of the binder.

Specification Details

Specification Details			Overall Frame Dimensions (mm)		
Arnos Code	Systems Shelf	Size	Height	Width	Depth
D057	Included	A0	1345	665	800
D058	Included	A1	1025	665	730
D054	Optional	A0	1330	665	800
D055	Optional	A1	1010	665	730

Assembly Chart

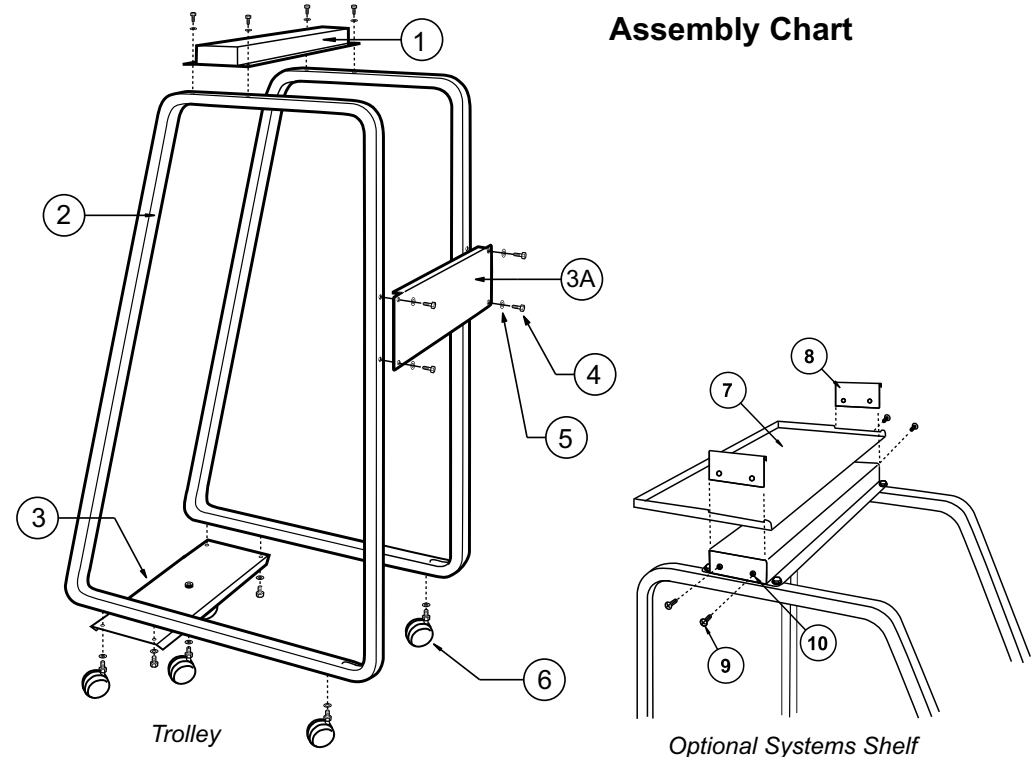

CONTENTS

1. Top Channel	x 1	Optional Systems Shelf:	
2. Side Frame	x 2	7. Systems Shelf	x 1
3A. Back Plate	x 1	8. Fixing Brackets	x 2
3B. Base Plate	x 1	9. 1/4" Combination Bolt	x 4
4. 8 x 20mm Hex Head Bolts	x 10	10. 1/4" Flat Washers	x 4
5. 8 x 16mm Flat Washers	x 15		
6. Castors	x 5		
Combination Spanner	x 1		